

U TYPE

REV.	DESCRIPTION	DRAWN	CHECKED	APPROVED
A	NEW RELEASE	LJH 09/15/05'	~	LJC 09/15/05'
B,C,D	ADD DIM.	LJH 04/04/06'	~	LJC 04/04/06'
F	ADD DIM.	LJH 04/15/06'	~	LJC 04/04/06'
G	整理图画	YCH 03/15/07'	~	LJC 03/15/07'
F	整理料号	YCH 07/11/07'	~	

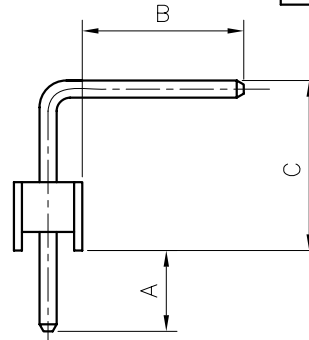
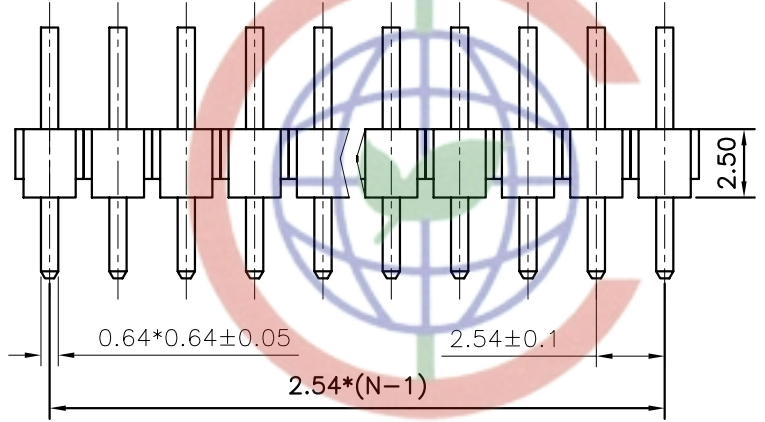

NOTES:

- MATERIALS
 - CONTACT MATERIAL: COPPER ALLOY.
 - INSULATOR: PBT
- SPECIFICATIONS
 - CURRENT RATING: 3A.
 - OPERATING TEMPERATURE: -40°C TO +105°C.
 - INSULATION RESISTANCE: 1000MΩ MIN.
 - CONTACT RESISTANCE: 20mΩ MAX.
 - DIELECTRIC WITHSTANDING: 600 VAC.
- PART NUMBER: DS1022
- PRODUCT NUMBER CODE:

TABLE A:

TYPE	Dimension			Pin Length (mm)
	A	B	C	
1	3.00	6.00	6.07	15.50
2	4.00	6.90	3.40	14.70
3	6.00	11.40	5.64	23.40
4	3.75	3.40	3.40	11.00
5	2.80	4.00	3.40	10.60
6	5.85	7.90	3.40	17.50
7	3.60	3.20	3.40	10.60
8	6.30	3.20	4.36	14.20
9	3.00	6.00	5.42	14.70
10	3.64	5.76	6.48	16.30
11	3.00	6.00	5.00	14.40
12	3.10	3.40	3.40	10.50
13	6.00	4.90	3.40	14.70
14	6.30	3.00	3.40	14.00
15	6.20	3.70	3.60	14.00
16	3.00	6.30	4.20	14.00
17	2.30	5.11	5.30	13.10
18	6.20	3.80	3.40	13.80
19	4.70	4.70	4.20	14.00
20				

普通

DS1022- X X U X X

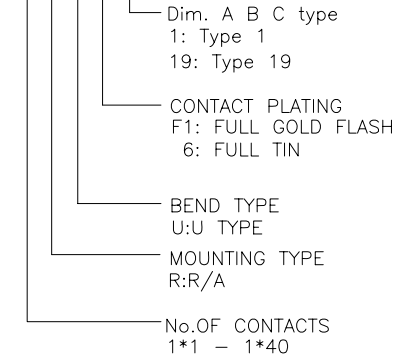

N: NUMBER OF CONTACTS
2.54*N REF

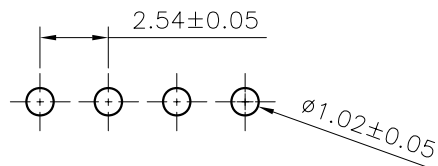
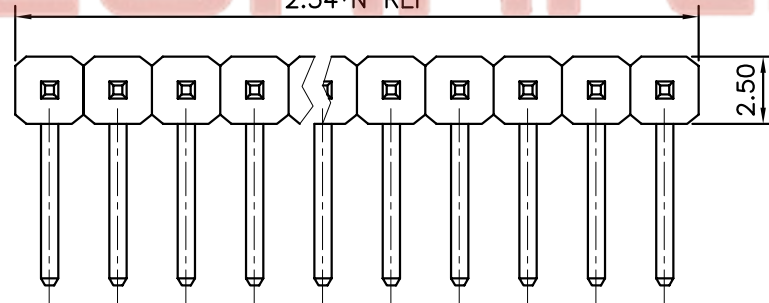

RECOMMEND P.C.BOARD LAYOUT

GENERAL TOLERANCE	ANGLE TOLERANCE	PROJECTION	TITLE
X. ±0.60	X. ±5°	mm	PIN HEADER PITCH 2.54mm R/A TYPE
.X ±0.38	.X ±3°	A4	SHEET SIZE
.XX ±0.25	.XX ±2°		SERIES DS1022 SERIES
DRAWING TYPE	CUSTOMER	晨翔电子有限公司 CONNFLY CONNFLY ELECTRONIC CO. LTD	
SCALE	1:1 SHEET 1 OF 1		
DRAWING NO.	C-DS1022-1*XXXUX		

86-574-63508787
Fax: 86-574-63510817

D TYPE

REV.	DESCRIPTION	DRAWN	CHECKED	APPROVED
A	NEW RELEASE	LJH 04/06/06'	~	LJC 04/06/06'
B	ADD DIM	LL 08/05/06'	~	LJC 04/06/06'
C	增加规格整理图面	YCH 03/15/07'	~	LJC 03/15/07'
D	整理料号	YCH 07/11/07'	~	

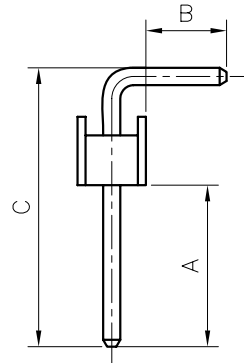
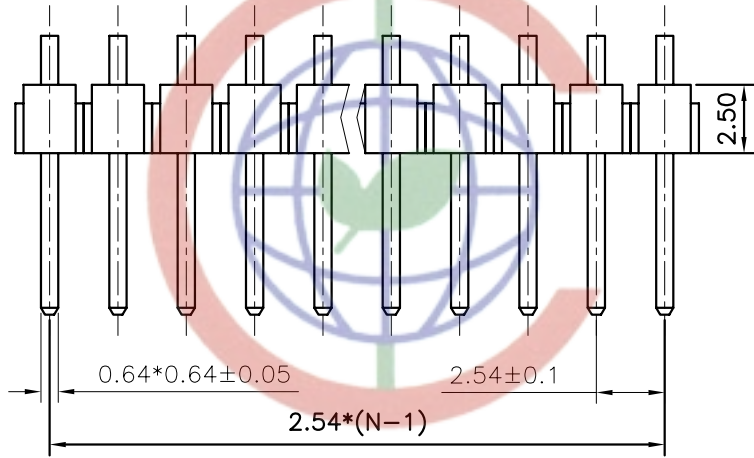

NOTES:

- MATERIALS
 - CONTACT MATERIAL: COPPER ALLOY.
 - INSULATOR:PBT
- SPECIFICATIONS
 - CURRENT RATING: 3A.
 - OPERATING TEMPERATURE: -40°C TO +105°C.
 - INSULATION RESISTANCE: 1000MΩ MIN.
 - CONTACT RESISTANCE: 20mΩ MAX.
 - DIELECTRIC WITHSTANDING: 600 VAC.
- PART NUMBER: DS1022
- PRODUCT NUMBER CODE:

TABLE A:

TYPE	Dimension			Pin Length (mm)
	A	B	C	
1	6.00	3.00	10.36	13.80
2	6.00	4.50	9.50	14.40
3	6.10	4.00	10.40	14.80
4	6.00	3.20	10.50	14.10
5	6.00	3.50	10.82	14.70
6	4.70	1.73	8.20	10.40
7	15.00	3.00	19.08	22.50
8	6.00	3.10	11.10	14.40
9	1.00	1.91	5.00	7.40
10	6.20	3.20	11.10	14.70
11	6.20	3.20	10.8	14.40
12	4.50	2.93	8.00	11.40
13	6.30	2.60	10.36	13.40
14	5.70	2.95	9.52	12.90
15	4.80	3.00	8.10	11.50
16	6.00	3.00	9.14	12.60
17	7.20	3.00	10.36	13.80
18	3.00	6.00	7.50	13.80
19				
20				

普通

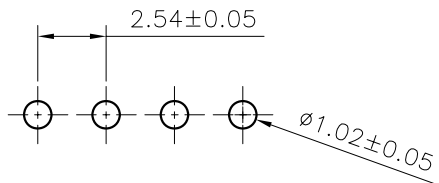
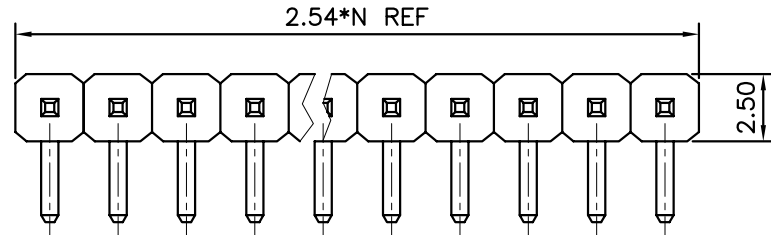
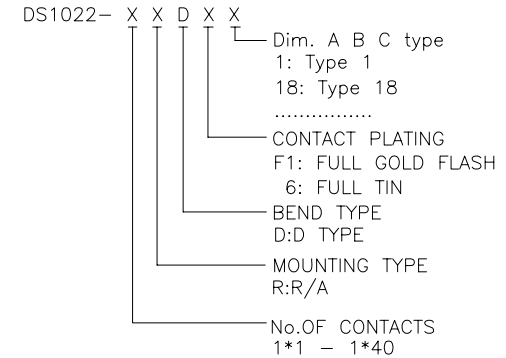

RECOMMEND P.C.BOARD LAYOUT

A/B/C:CUSTOMER LENGTH AVAILABLE

GENERAL TOLERANCE	ANGLE TOLERANCE	PROJECTION	TITLE
X. ±0.60	X. ±5°	UNITS mm	PIN HEADER PITCH 2.54mm R/A TYPE
.X ±0.38	.X ±3°	SHEET SIZE A4	SERIES DS1022 SERIES
.XX ±0.25	.XX ±2°	晨翔电子有限公司 CONNFLY CONNFLY ELECTRONIC CO. LTD	
DRAWING TYPE	CUSTOMER		
SCALE	1:1 SHEET 1 OF 1		
DRAWING NO.	C-DS1022-1*XXXDX		

TEL: 86-574-63508787
 Fax: 86-574-63510817

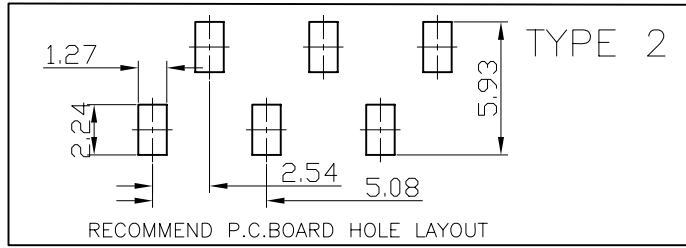
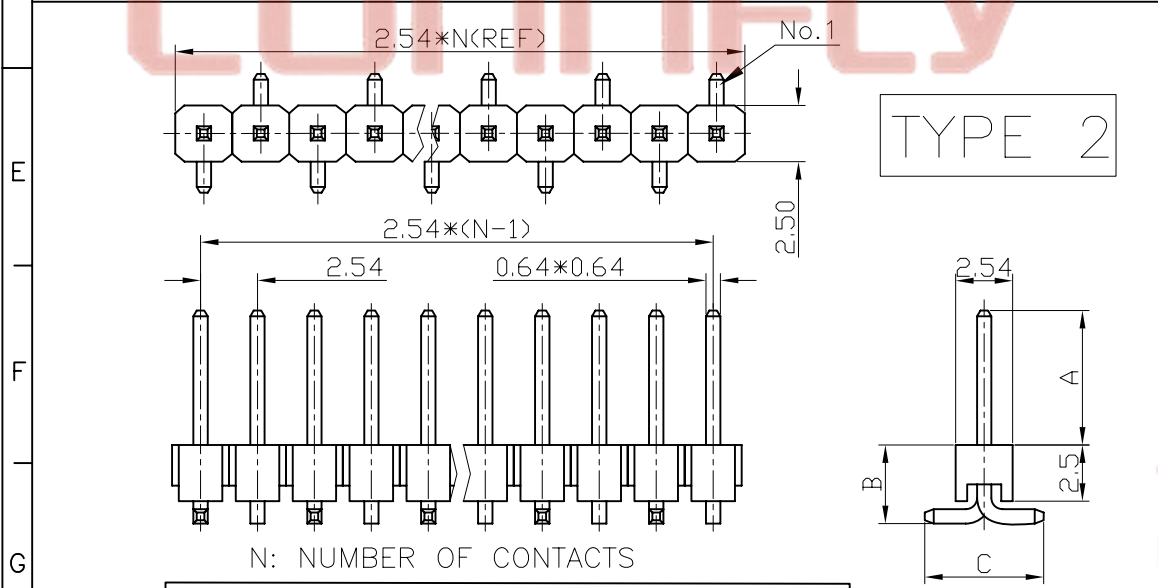
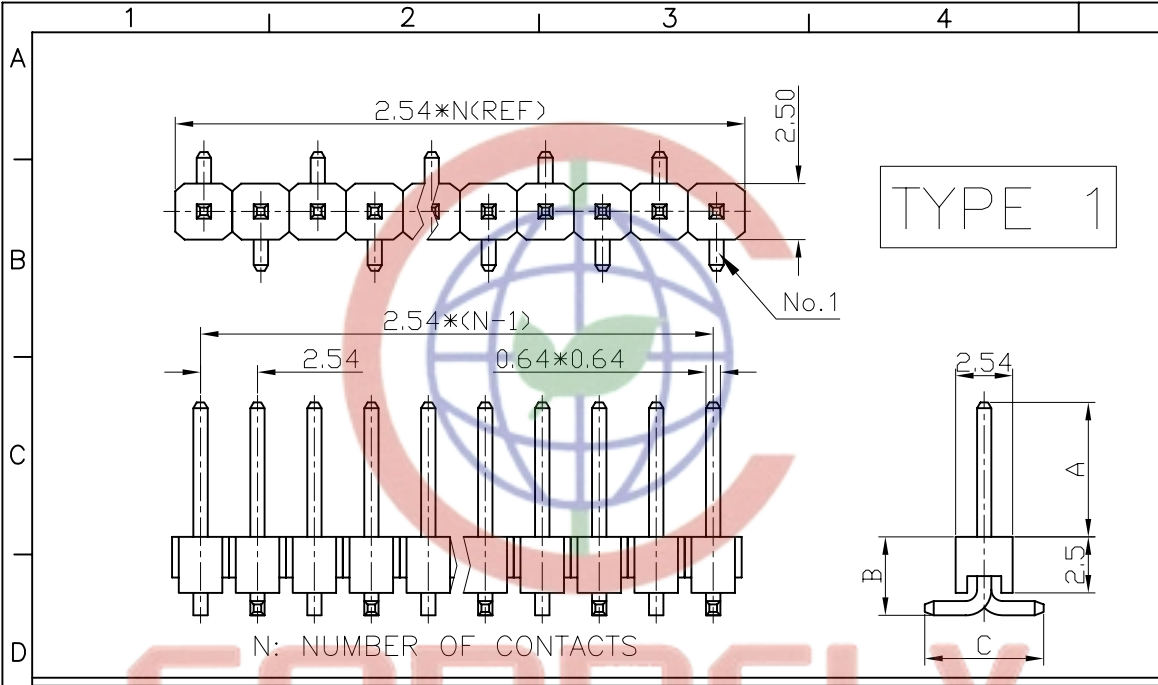

REV.	DESCRIPTION	DRAWN	CHECKED	APPROVED
A	NEW RELEASE	YCH 01/18/08'	~	

- NOTES:
- MATERIALS
 - CONTACT MATERIAL: COPPER ALLOY.
 - CONTACT PLATING: GOLD/TIN OVER NICKEL.
 - INSULATOR MATERIALS: PBT.
 - SPECIFICATIONS
 - CURRENT RATING: 3 A.
 - OPERATING TEMPERATURE: -40°C TO +105°C.
 - INSULATION RESISTANCE: 1000MΩ MIN.
 - CONTACT RESISTANCE: 20mΩ MAX.
 - DIELECTRIC WITHSTANDING : 600 VAC.
 - CONTACT INSERTION FORCE PER PIN: 1kgf min.
 - PRODUCT NUMBER CODE:

TABLE A:

TYPE	Dimension			Pin Length (mm)
	A	B	C	
1	6.00	3.50	5.30	11.30
2	6.00	4.30	4.90	11.90
3				
4				
5				
6				
7				
8				
9				
10				
11				
12				
13				
14				
15				
16				
17				
18				
19				
20				
21				
22				
23				
24				
25				
26				
27				
28				
29				
30				
31				
32				
33				
34				

普通

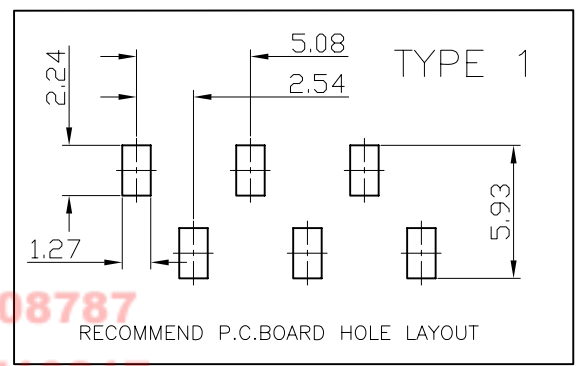
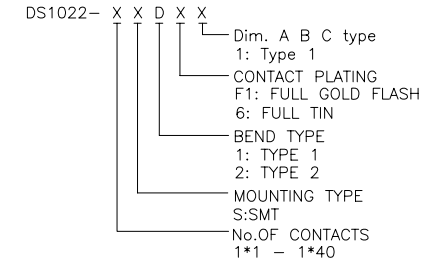

GENERAL TOLERANCE	ANGLE TOLERANCE	PROJECTION	TITLE
X. ±0.60	X. ±5°	UNITS	PIN HEADER PITCH 2.54mm SMT TYPE
.X ±0.38	.X ±3°	SHEET SIZE	A4
.XX ±0.25	.XX ±2°	SERIES	DS1022 SERIES
DRAWING TYPE	CUSTOMER	晨翔电子有限公司 CONNFLY CONNFLY ELECTRONIC CO. LTD	
SCALE	1:1	SHEET	1 OF 1
DRAWING NO.	C-DS1022-1*XXXXX		

REV.	DESCRIPTION	DRAWN	CHECKED	APPROVED
A	NEW RELEASE	LJH 09/21/05'	~	LJC 09/21/05'
B,C	ADD DIM.	LJH 04/04/06'	~	LJC 04/04/06'
D	ADD DIM.	LL 09/26/06'	~	LJC 09/26/06'
E	整理图面	YCH 03/15/07'	~	LJC 03/15/07'
F	增加SMT尺寸值表格	YCH 05/18/07'	~	LJC 05/18/07'
G	整理图面	YCH 07/23/08'	~	

RIGHT ANGLE TYPE
N:NUMBER OF CONTACT/2

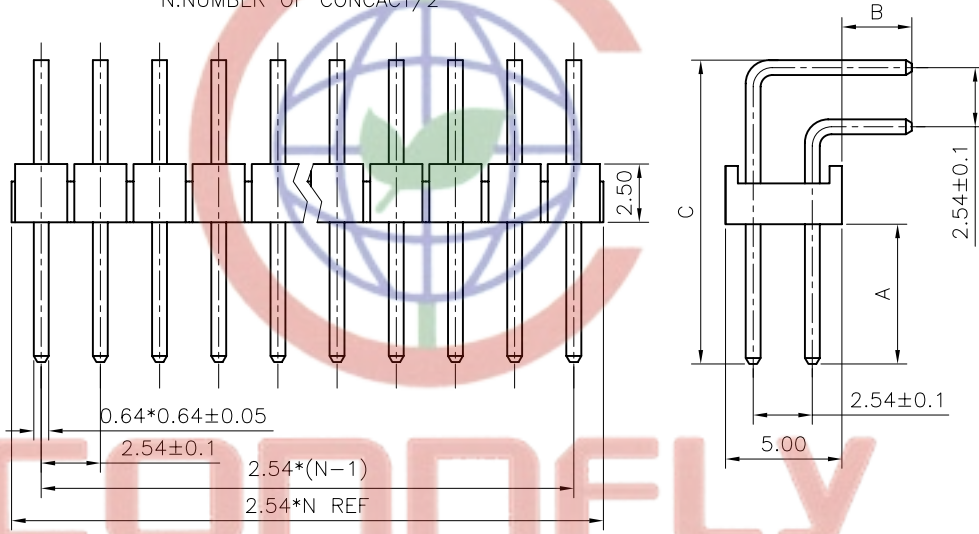

RIGHT ANGLE
TABLE A:

TYPE	Dimension			Pin Length (mm)
	A	B	C	
1	6.00	3.00	13.04	14.00 19.00
2	6.10	4.00	12.94	14.80 19.90
3	6.00	4.00	12.76	14.70 19.70
4	9.00	3.00	16.04	16.90 22.00
5	6.00	3.00	13.80	14.70 19.80
6	5.10	3.00	13.04	14.00 19.00
7	6.50	3.00	13.10	14.00 19.00

NOTES:

- MATERIAL
 - INSULATOR:
 - DIP TYPE:PBT G.F30% UL 94-V0 MELT TEMPERATURE 225°C.
 - SMT TYPE:PA-46 G.F30% UL 94-V0 MELT TEMPERATURE 270°C.
 - CONTACT: COPPER ALLOY.
- SPECIFICATION
 - STORAGE TEMPERATURE: -20-70°C.
 - OPERATING TEMPERATURE: 0-85°C.
 - CONTACT RESISTANCE: 20mΩ max.
 - INSULATION RESISTANCE:1000MΩ min.
 - DIELECTRIC WITHSTANDING VOLTAGE: AC 500V PER MINUTE.
- PART NUMBER: DS1022
- PRODUCT NUMBER CODE:

DS1022- X X X X
 Dim. A B C type
 1: Type 1
 6: Type 6

 CONTACT PLATING
 F1: FULL GOLD FLASH
 6: FULL TIN
 MOUNTING TYPE
 M: SMT
 R: RIGHT ANGLE
 No. OF CONTACTS
 2*2 - 2*40
 3*2 - 3*40

SMT TYPE
N:NUMBER OF CONTACT/2

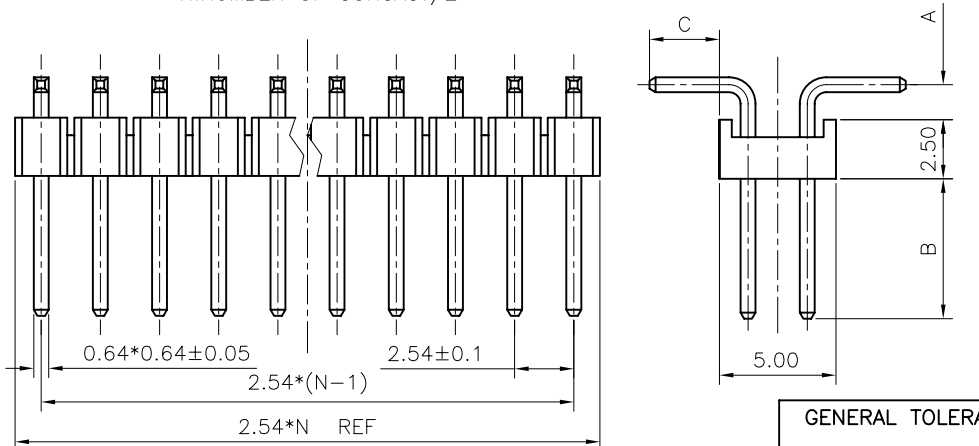

SMT
TABLE B:

TYPE	Dimension			Pin Length (mm)
	A	B	C	
1	1.50	6.00	3.00	13.80
2	1.20	6.00	3.00	13.50
3				
4				
5				
6				
7				
8				
9				

GENERAL TOLERANCE		ANGLE TOLERANCE		PROJECTION		TITLE	
X.	±0.60	X.	±5'	UNITS	mm	PIN HEADER PITCH 2.54mm R/A&SMT TYPE	
.X	±0.38	.X	±3'	SHEET SIZE	A4	SERIES	DS1022 SERIES
.XX	±0.25	.XX	±2'				
DRAWING TYPE		CUSTOMER		晨翔电子有限公司 CONNFLY CONNFLY ELECTRONIC CO. LTD			
SCALE		1:1					
DRAWING NO.		C-DS1022-2*XXXX-G					

Tel: 86-574-63508787
 Fax: 86-574-63510817